

Technical data-sheet for welding-pincer SZ-2002

Manufacture:

KombiTec GmbH

An der Römerstr. 1

D-87488 Betzigau

GERMANY

Tel: +49 (0) 831 / 960 398 - 0

Fax: +49 (0) 831 / 960 398 - 10

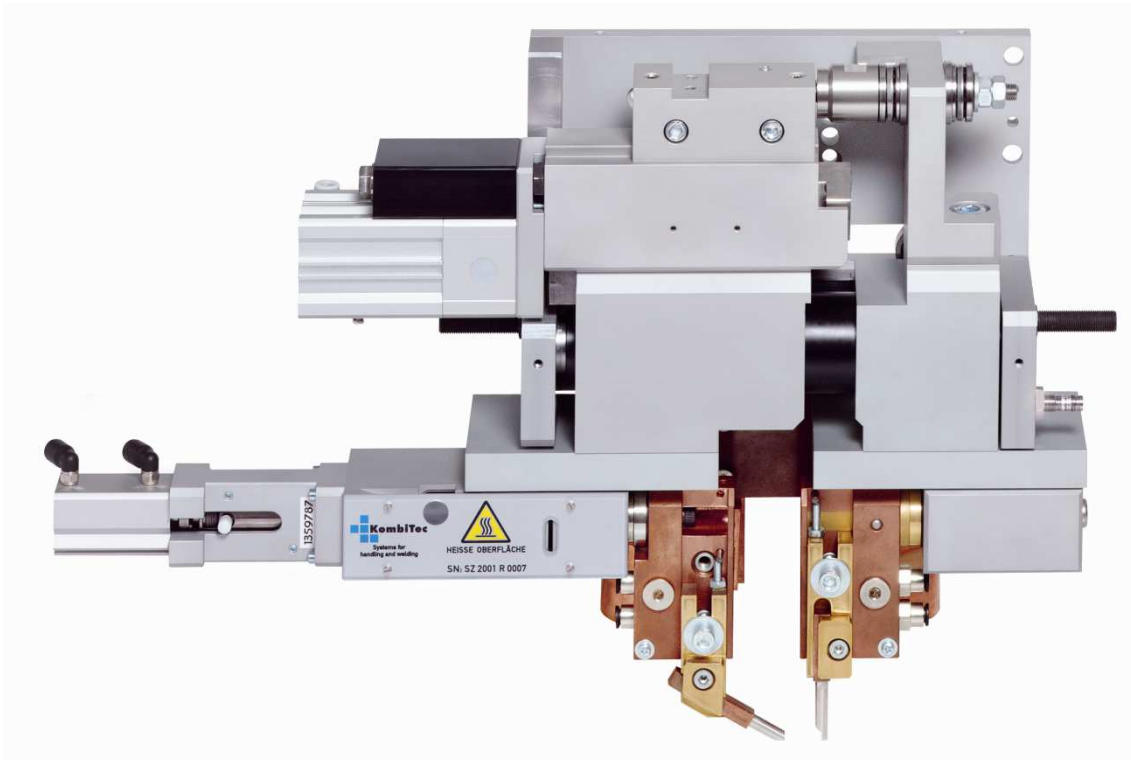

Benefits:

- Welding-pincer with welding-forces up to 200N
- Due to modular principle highest compatibility to other KombiTec products
- Compact, but highly flexible construction with lowest possible weight
- Precise positioning-accuracy, stability and robustness due to pre-stressed roller-bearings
- Stroke-module for separate movement of right-sided electrode-holder
- weight-levelling available if mounting is vertical
- electrode-holders are possible to swivel separate
- Best reproducibility by plunging scenes
- Due to loaded springs fastest response while welding
- simple upgrade-opportunity for displacement-sensors

Application areas:

Suitable for weldings especially in sub-optimal reachable positions. Typical applications for these high-performance-pliers are:

- Light industry: Tungsten-filaments welded to molybdenum pins
- Automotive: moulded stamped parts welded with sensors
- Electric / Electronical: elements and wires to circuit boards or substrates
- Energy technique: contacts for solar power generators and equipment
- Production of sensors: micro-, small- and medium-size applications
- Consumer goods production: small size spot welding applications

Optional available:

- „Swimming“-positioning-unit
- Digital displacement-sensors (resolution 1,0µm)
- Portal to mount plier horizontal or vertical
- Portal to swiveling plier

Technical changes:

Technical modification and price changes without notices. All dimensions are in „mm“. No liability can be accepted for printing errors.

Technical data:

Cylinder-diameter working stroke:	Ø 32mm
Working pressure:	3 – 7 bar
Pressing force between electrodes:	closing max. 245N (at 5,0bar)
Medium pressed air:	filtered 5µm, free of water / dried, oiled or un-oiled
Pneumatic hose:	Ø 6 mm
Working temperature:	0°C – 60°C
Repeatability:	± 0,10mm
Working temperature:	0°C – 60°C
Max. stroke of electrodes:	30,0mm
Max. displacement-stroke:	3,5mm
Air-consumption per cycle:	approx. 0,15 ltr (at 5,0 bar and max. stroke)
Total weight:	ca. 10,5 kg (net)

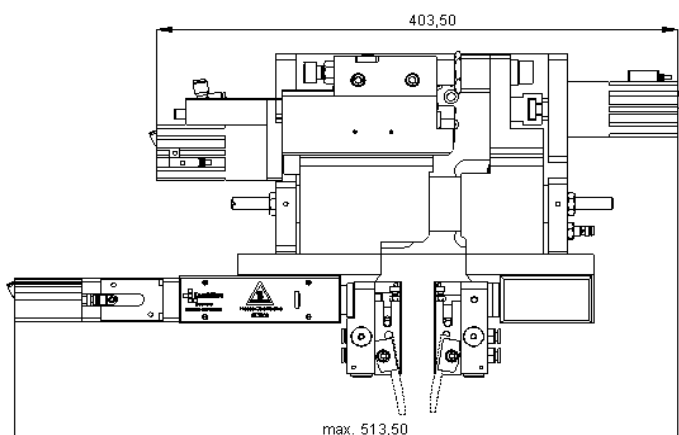
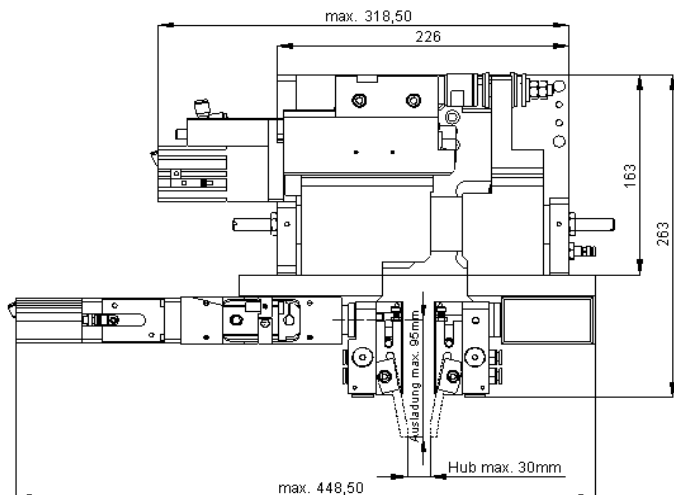

Displacement-spring

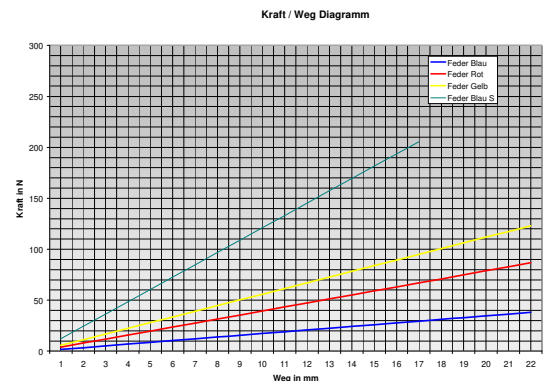

Picture: Dimension welding-pincer SZ-2002 with pneumatic drive, without mounted attachments

Welding-pincer SZ-2002

Option of configuration:

