

Technical data-sheet for welding-head SK-2350

Manufacture:

KombiTec GmbH
An der Römerstr. 1
D-87488 Betzigau
GERMANY
Tel: +49 (0) 831 / 960 398 - 0
Fax: +49 (0) 831 / 960 398 – 10

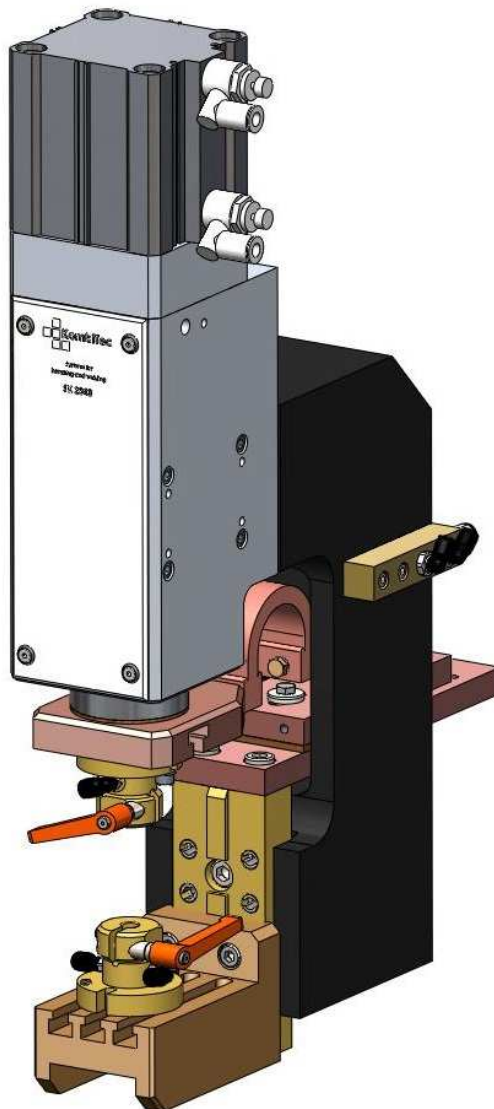

Benefits:

- Welding-head for up to max. 3.500 N welding force
- Due to modular principle highest compatibility to other KombiTec products
- Compact, but highly flexible construction with lowest possible weight
- Precise positioning-accuracy, stability and robustness due to pre-stressed ball-bearings
- Highest reproducibility through shape-connection
- Outstanding displacement behaviour due to unstressed anti-torsion units
- Simple adjusting of sensors
- various opportunities to monitor displacement-distance with high-speed distance-sensors

Application areas:

Suitable for all standard weldings, like:

- Automotive industry: welding of car-body sheets to frame
- Home-appliances industry: Welding of pot-handles, heater, wash-machine housings

Technical changes:

Technical modification and price changes without notices. All dimensions are in „mm“.
No liability can be accepted for printing errors.

Technical data:

Infeed unit:	pneumatically cylinder, available cylinder and corresponding forces are: → Ø63mm → 1.500,0 N → Ø80mm → 2.500,0 N
Medium pressed air:	filtered 5µm, free of water / dried, oiled or un-oiled
Pneumatic fittings:	G1/4"
Pneumatic hose:	Ø 6 mm
Working pressure:	3 – 7 bar
Working temperature:	0°C – 60°C
Repeatability:	± 0,01 mm
Max. weight of electrode holders:	< 1,0 kg
Max. stroke:	20 mm
Air consumption per cycle:	0,15 L (at 5 bar and max. stroke)
Total weight:	11,5 kg (with electrode-base-holder, but without welding-head stator)

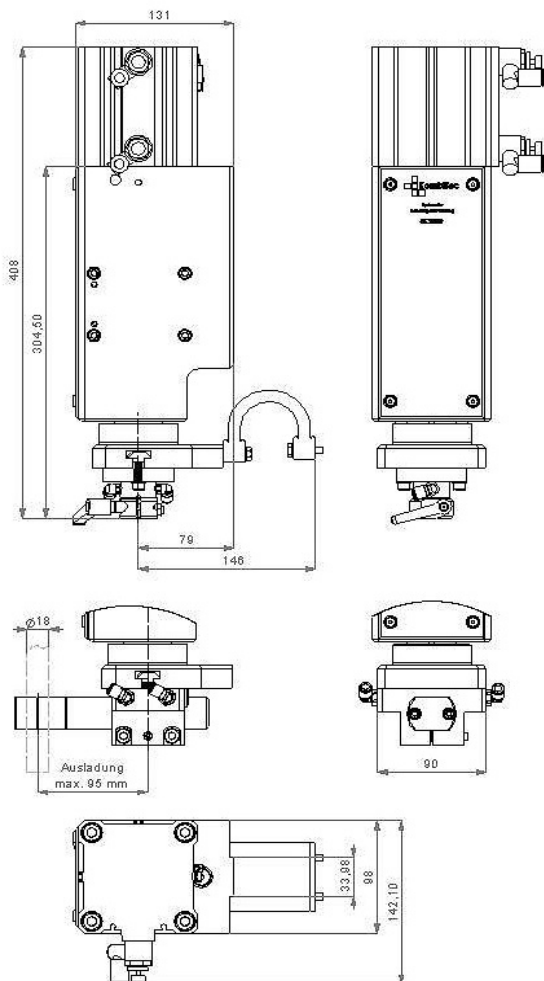

Picture: Dimension welding head SK-2020 without fixing/ mountings

Welding-head SK-2350

Option of configuration:

**Pneumatic cylinder Ø80
SK-2350-RZ-100 or
Ø63 SK-2110-RZ-050**

**Welding-head stator
SK-2110-RG-000 / SG-xxx**

**Displacement-sensor unit
SK-2110-WS-xxx**

**Displacement-spring
SK-2110-RR-xxx**

**Copper-connection
SK-2110-KB-000**

**Electrode-base-holder,
with/without cooling
SK-2350-RO-xxx**

**Electrode-holder, top
SK-2110-EO-xxx / SK-2350-EO-xxx**

**Electrode-holder, bottom
SK-2110-RU-xxx/ SK-2350-EU-xxx**

**Konsolenarmatur, für Sonder-
ständer S-2110-RK-xxx**

